

# EUCLID IN A NUTSHELL



Schweizerische Eidgenossenschaft  
Confédération suisse  
Confederazione Svizzera  
Confederaziun svizra

Swiss Confederation

Federal Department of Economic Affairs,  
Education and Research EAER  
State Secretariat for Education,  
Research and Innovation SERI

Swiss Space Office

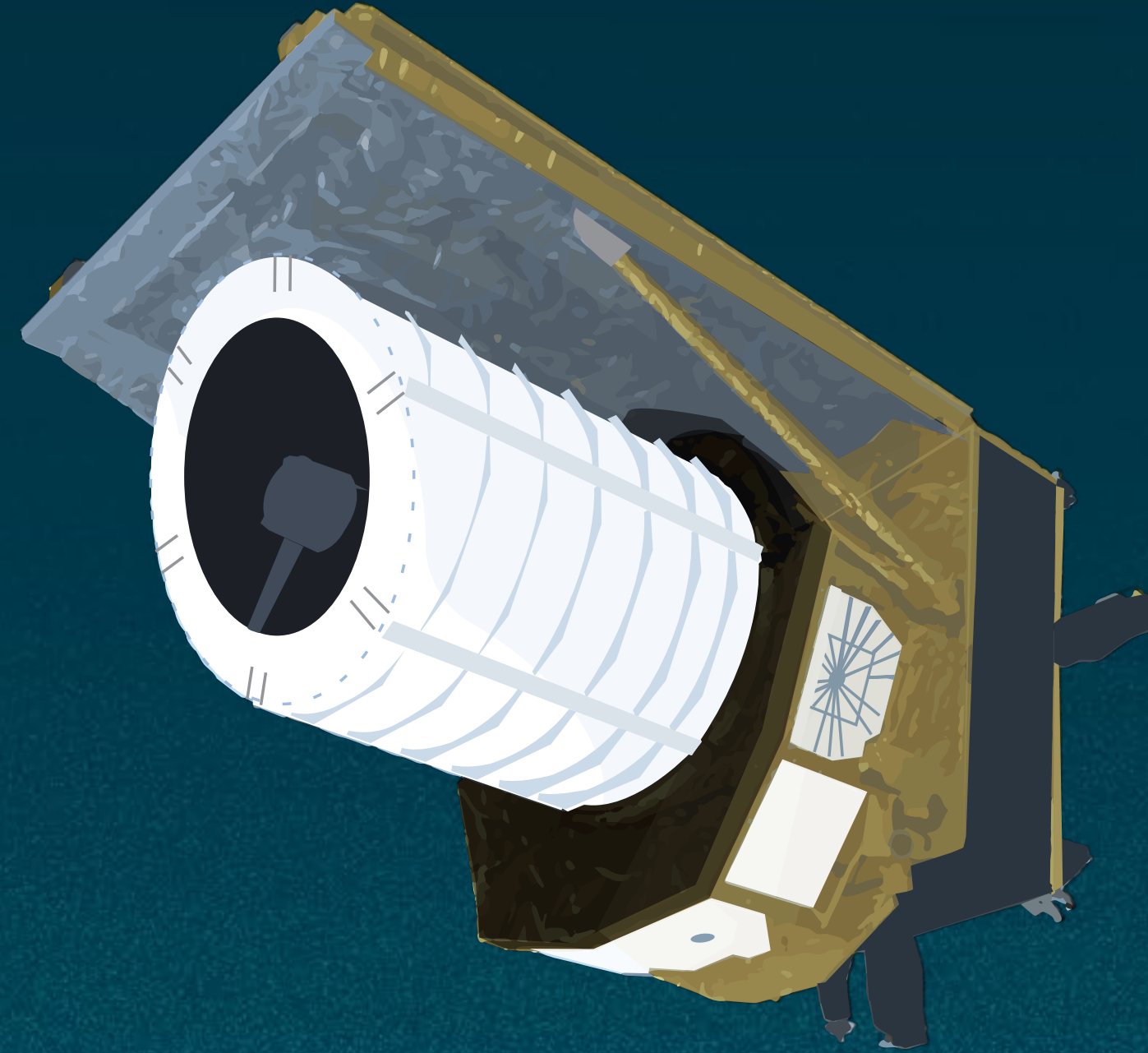

The space telescope will create an extensive map of the large-scale structure of the Universe across space and help us to understand 2 mysterious components: dark matter and dark energy.



**Euclid is an ESA mission with contributions from Swiss partners**



► At the beginning of July 2023 Euclid launches on a SpaceX Falcon 9 rocket from Cape Canaveral Space Force Station in Florida, USA

► Its destination is Sun-Earth Lagrange point 2, 1.5 million km from Earth

► Four Swiss academic institutions contribute to Euclid, with University of Geneva as the leading institution.

► Euclid is an ESA mission, with 2 science instruments:  
1 VISible-wavelength camera (VIS)  
1 Near-Infrared Spectrometer and Photometer (NISP)  
NASA provided the near-infrared detectors of NISP.

## Euclid will:



Observe 1/3 of the sky



Measure the shape, position and distance of galaxies out to 10 billion light-years



Create the largest, most accurate 3D map of the Universe ever produced

## Euclid will address two core themes of ESA's Cosmic Vision 2015–2025:

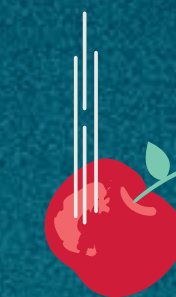

What are the fundamental physical laws of the Universe?

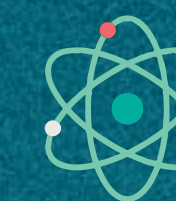

How did the Universe originate and what is it made of?





ESA Launch kit



Schweizerische Eidgenossenschaft  
Confédération suisse  
Confederazione Svizzera  
Confederaziun svizra

Swiss Confederation

Federal Department of Economic Affairs,  
Education and Research EAER  
State Secretariat for Education,  
Research and Innovation SERI

Swiss Space Office



Contact: [space@sbfi.admin.ch](mailto:space@sbfi.admin.ch)

## University of Geneva

Astrophysicists have:

- ▶ developed a key product, dedicated algorithms to measure the distance of billions of galaxies;
- ▶ provided guidance on the scientific objectives and devised methods for observation.

UniGE is responsible for the mechanical shutter of the VIS optical imager, with extreme reliability and precision requirement.

[stephane.paltani@unige.ch](mailto:stephane.paltani@unige.ch) &  
[martin.kunz@unige.ch](mailto:martin.kunz@unige.ch)

## University of Zurich

Researchers have been preparing for the expected observations of Euclid. They have created and tested advanced computer simulations that replicate how galaxies are distributed in space.

Cosmologists study how Euclid's observations can be used to investigate the properties of the dark matter in our Universe.

They examine the impact that "relativistic effects" have on Euclid's observations. These effects occur because light from galaxies must travel through a Universe where matter is not evenly distributed to reach the telescope.

[francesca.lepori2@uzh.ch](mailto:francesca.lepori2@uzh.ch) &  
[joachimgerhard.stadel@uzh.ch](mailto:joachimgerhard.stadel@uzh.ch)

## Fachhochschule Nordwestschweiz

Data scientists have been implementing key components for processing Euclid data in computing centers spread around the globe.

They manage the extremely complex workflow of the Euclid data processing pipeline. In addition, the team has developed deep learning models that aim at automatically identifying different types of galaxies from the huge amount of image data observed by Euclid.

[martin.melchior@fhnw.ch](mailto:martin.melchior@fhnw.ch)

## École polytechnique fédérale de Lausanne

Scientists are focusing on the phenomenon of strong gravitational lensing. This occurs when a massive galaxy (the lens), a group of galaxies or a cluster of galaxies deviate light rays from another source of light in the background.

Strong lenses offer many scientific applications. They can be used as a natural (gravitational) telescope that naturally magnifies distant objects. They can be used e.g to measure the expansion rate of the Universe, known as the Hubble constant.

However, strong lenses are rare: among the billions of galaxies Euclid will see, only 100'000 such objects are expected. EPFL is in charge of finding them with artificial intelligence techniques.

[frederic.courbin@epfl.ch](mailto:frederic.courbin@epfl.ch)

Swiss companies contributing to various systems with their technological expertise include: APCO Technologies, Beyond Gravity, SCHOTT and former Syderal Swiss.

Euclid is a European mission, built and operated by ESA, with contributions from NASA. The Euclid Consortium consists of more than 2000 scientists from 300 institutes in 13 European countries, the US, Canada and Japan. Swiss participation to Euclid is enabled by Switzerland's membership in ESA, and was supported via the ESA PRODEX and the SNF Sinergia programmes.